

290 Series Impact Wrench Exploded - View

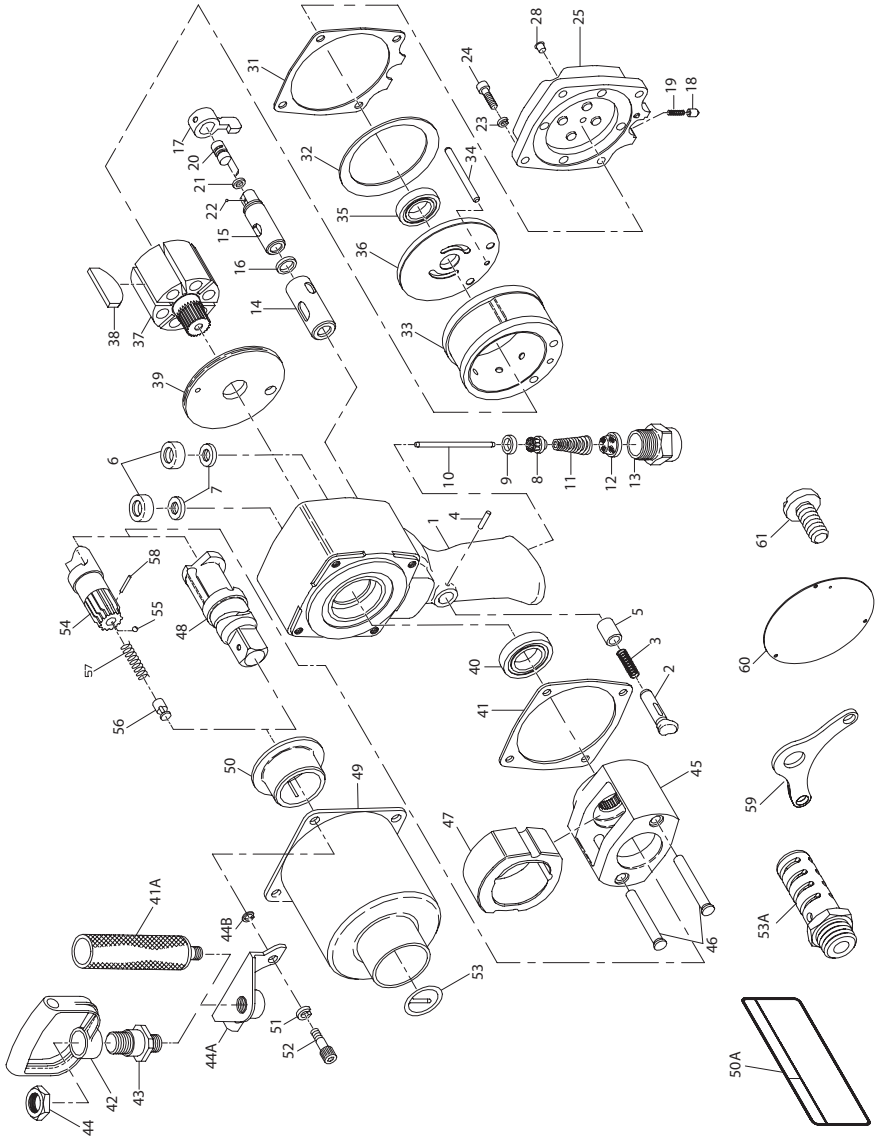

(Dwg. TPA1178-5)

290 Series Impact Wrench - Parts List

Item	Part Description	Part Number	Item	Part Description	Part Number
1	Motor Housing Assembly	1712P-A40	44	Side Spade Handle Nut	107-73A
2	Trigger	2934P-93	44A	Side Spade Handle Bracket	2934-364
3	Trigger Spring	2934P-51	44B	Hanger Spacer (2)	2934-140
4	Trigger Pin	R1AF-524	45	Hammer Frame Assembly	2934-A703
5	Trigger Bushing	2905-91S	46	Hammer Pin (2)	2934-704
6	Air Port Gasket (2)	R44H-210A	47	Hammer	1712-724
7	Gasket Retainer (2)	2940-200	48	1" Square Drive Anvil	
8	Throttle Valve Assembly	2934P-A50		Standard length	1712-726
• 9	Throttle Valve Face	2934-159		6" extended length	280-726-6
• 10	Throttle Valve Plunger	2934P-302	49	Hammer Case Assembly	
11	Throttle Valve Spring	834-51		for 290, 290-6 and 290-S	1712B-A727
• 12	Air Strainer Screen	434-61		for 290-EU and 290-6-EU	1712B-EU-A727
13	Straight Inlet	845-565	50	Hammer Case Bushing	2934-641
• 14	Reverse Valve Bushing	2934P-3305	50A	Hammer Case Label	
15	Reverse Valve Assembly	2934P-A329		for 290, 290-6 and 290-S	WARNING-2-99
16	Reverse Valve Seal	85H-167		for 290-EU and 290-6-EU	EU-99
17	Reverse Lever	2934-658A	51	Hammer Case Cap Screw Lock	34U-58
18	Reverse Lock Plunger	4U-663B		Washer (4)	
• 19	Reverse Lock Spring	4U-664	52	Hammer Case Cap Screw (4)	834-638
	Power Regulator Assembly	2934P-A249	53	Socket Retainer	RR100155
• 20	Power Regulator	2934P-249	53A	Muffler	2910-674
• 21	Power Regulator Seal	R1A-159	54	Spline Drive Anvil	
22	Power Regulator Retaining Ball	AV1-255		Standard length	1712-A526
23	Housing Cover Lock Washer (4)	8U-58		6" extended length	280-A514-6
• 24	Housing Cover Cap Screw (4)	510-638	55	Socket Retaining Ball	D04-280
• 25	Housing Cover Assembly	1712P-A102	56	Retaining Ball Plunger	845-230
28	Grease Fitting	1305R-188	57	Retaining Plunger Spring	2940-231
31	Housing Cover Gasket	2934-283	58	Plunger Retaining Pin	845-128
32	Motor ClampWasher	2934-207	59	Horizontal Hanger	2934-366
• 33	Cylinder	2934-3	60	Nameplate	
• 34	Cylinder Dowel	2934-98		for 290-6	290-301-6
35	Rear Rotor Bearing	508-97		for 290-6-EU	290-6-EU-301
36	Rear End Plate	2934-12		for 290 and 290-S	290-301
37	Rotor	2934-53		for 290-EU	290-EU-301
• 38	Vane Packet (set of 6 Vanes)	2934-42-6		61	Nameplate Screw (3)
39	Front End Plate	2934-11	*	Tun-up Kit (includes illustrated parts	2940-TK3
40	Front Rotor Bearing	810-97		3, 4, 6 [2], 7 [2], 9, 11, 12, 27, 16, 21,	
• 41	Hammer Case Gasket	2934-36		22, 18, 19, 30, 31, 35, 38, 40 and 41)	
41A	Dead Handle	834-48			
42	Side Spade Handle	T15-41			
43	Side Spade Handle Stud	534-448			

* Not Illustrated.

To keep downtime to a minimum it is desirable to have on hand certain repair parts. We recommend that you stock one (pair or set) of each Part indicated by a bullet (•) for every four tools in service.

Parts and Maintenance

When the life of the tool has expired, it is recommended that the tool be disassembled, degreased and parts be separated by material so that they can be recycled.

Tool repair and maintenance should only be carried out by an authorized Service Center.

Refer all communications to the nearest **Ingersoll Rand** Office or Distributor.

Related Documentation

For additional information refer to: Air Impact Wrench Product Safety Information Manual 04580916.

Air Impact Wrench Product Information Manual 16581969.

Manuals can be downloaded from www.ingersollrandproducts.com.



www.ingersollrandproducts.com
© 2009 **Ingersoll Rand** Company

03527843
Edition 17
August 2009